



IMV VIBRATION
TEST SYSTEMS

A series

Air-cooled Vibration Test Systems

A65/SA5HAG A65/EM5HAG



A-series is the “new standard” in vibration testing, with a solid test performance. A-series increases the relative excitation force and has a displacement of 76.2 mmp-p (3 inch stroke) *1 which gives good balance between specification of velocity, acceleration and displacement. It also provides a maximum of 3.5 m/s shock velocity testing, which responds to the demand in lithium battery testing. Rapid creation of a test from a set of pre-defined templates conforming to most international test standards. Simply select the standard required to generate the main test settings.

*1) Only for A30, A45, A65, A74

1. Improvement of performance

Expansion of test cases and responses to high spec. tests allow the A-series to meet a wide range of testing needs.

- Improvement in excitation force
- Standard 76.2 mmp-p displacement
- Expansion in frequency range
- High velocity shock test

2. User friendly and secure

Greater security and functionality with improved energy savings.

3. User first principle

Intuitive interface guides the operator for easy use.

Comparison of consumed power per excitation force

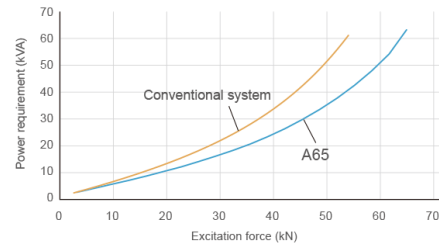



**IMV VIBRATION
TEST SYSTEMS**
A series

Air-cooled Vibration Test Systems

A65/SA5HAG A65/EM5HAG



System Specification			
System Model		A65/ SA5HAG	A45/ EM4HAG
Frequency Range (Hz)		0- 2,600*4	0-2,600*4
Rated Force	Sine (kN)	65	65
	Random (kN rms) *1	65	65
	Shock (kN)	130	130
	High Velocity Shock (kN) *5	-	120
Maximum Acc.	Sine (m/s ²)	900	900
	Random (m/s ² rms)	630	630
	Shock (m/s ²)	1,806	1,806
	High Velocity Shock (m/s ² peak) *5	-	1,666
Maximum Vel.	Sine (m/s)	2.0	2.0
	Shock (m/s peak)	2.5	2.5
	High Velocity Shock (m/s peak) *5	-	3.5
Maximum Disp.	Sine (mmp-p)	76.2	76.2
	High Velocity Shock (mmp-p)	-	76.2
Maximum Travel (mmp-p)		82	82
Maximum Load (kg)		1,000	1,000
Power Requirements (kVA) *2		83	83
Breaker Capacity (A) *3		150	150

Vibration Generator (A65)	
Armature Mass (kg)	72
Armature Diameter (φ mm)	446
Armature Resonance (Hz)	1,770
Allowance Eccentric Moment (N·in)	1,550
Mass (kg)	4,200

Power Amplifier	SA5HAG- A65	EM5HAG- A65
Maximum Output (kVA)	68	
Mass (kg)	1,000	1,150

Cooling (VAPE800/N2R)		
Mass (kg)	268	
Cooling Air Flow (m ³ /min)	66	
Environmental Data		
Input Voltage Supply (3 φ, V)	380/400/415/440	
Compressed Air Supply (Mpa)	0.7	
Working Ambient Temperature	Shaker (°C)	0-40
	Amplifier (°C)	0-40

Vibration Generator (A65) a: W 1,310 mm
b: H 1,253 mm
c: D 1,040 mm

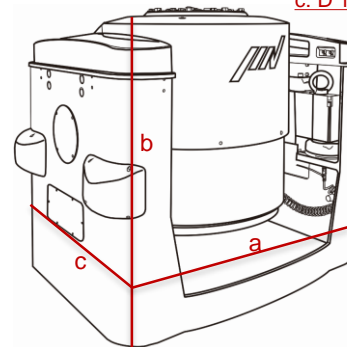
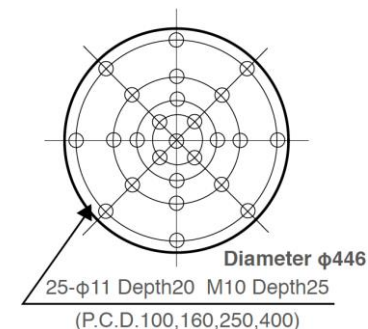
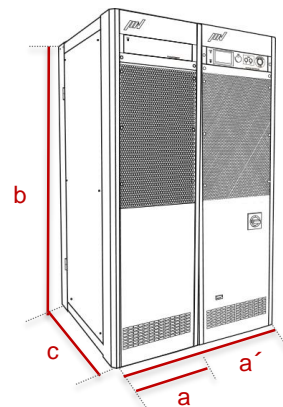

Table Insert Pattern (unit: mm)



Amplifier



SA5HAG-A45

a: W 580 mm
b: H 1,950 mm
c: D 850 mm

EM5HAG-A65

a': W 1,160 mm
b: H 1,950 mm
c: D 850 mm

Blower

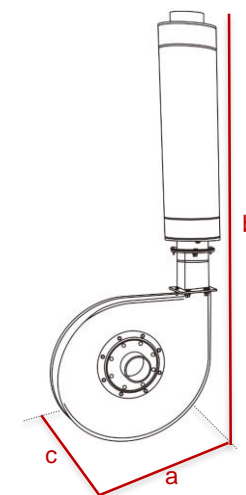

a: W 1,294 mm
b: H 2,540 mm
c: D 871 mm

*1 Random force ratings are specified in accordance with ISO5344 conditions. Please contact IMV or your local distributor with specific test requirements.
*2 Power supply: 3-phase 380/400/415/440 V, 50/60 Hz. A transformer is required for other supply voltages.
*3 Breaker capacity for 480 V.
*4 Maximum velocity 4.6 m/s. High velocity restricts maximum Shock force.
*5 The specification shows the maximum system performance. For long-duration tests, system must be de-rated up to 70%.
Continuous use at maximum levels may cause failure. Please contact IMV if your system operates at more than 70%.
*For random vibration tests, please set the test definition of the peak value of acceleration waveform to operate at less than the maximum acceleration of shock.
*Frequency range values vary according to the sensor and vibration controller.
*Armature mass and acceleration may change when a chamber is added.