



IMV VIBRATION
TEST SYSTEMS

A series

Air-cooled Vibration Test Systems

A74/EM10HAG



A-series is the “new standard” in vibration testing, with a solid test performance. A-series increases the relative excitation force and has a displacement of 76.2 mmp-p (3 inch stroke) *1 which gives good balance between specification of velocity, acceleration and displacement. It also provides a maximum of 3.5 m/s shock velocity testing, which responds to the demand in lithium battery testing. Rapid creation of a test from a set of pre-defined templates conforming to most international test standards. Simply select the standard required to generate the main test settings.

*1) Only for A30, A45, A65, A74



1. Improvement of performance

Expansion of test cases and responses to high spec. tests allow the A-series to meet a wide range of testing needs.

- Improvement in excitation force
- Standard 76.2 mmp-p displacement
- Expansion in frequency range
- High velocity shock test

2. User friendly and secure

Greater security and functionality with improved energy savings.

3. User first principle

Intuitive interface guides the operator for easy use.

Comparison of consumed power per excitation force

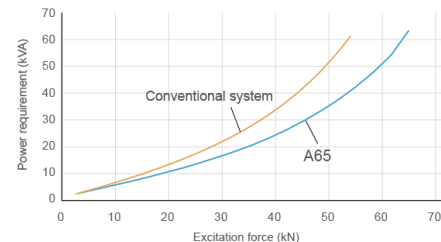

IMV CORPORATION



**IMV VIBRATION
TEST SYSTEMS**
A series

Air-cooled Vibration Test Systems

A74/EM10HAG



System Specification		
System Model	A74/EM10HAG	
Frequency Range (Hz)	0-2,600 ^{*4}	
Rated Force	Sine (kN)	74
	Random (kN rms) ^{*1}	74
	Shock (kN)	222
	High Velocity Shock (kN) ^{*5}	170
Maximum Acc.	Sine (m/s ²)	1,000
	Random (m/s ² rms)	630
	Shock (m/s ²)	2,000
	High Velocity Shock (m/s ² peak) ^{*5}	2,000
Maximum Vel.	Sine (m/s)	2.0
	Shock (m/s peak)	2.5
	High Velocity Shock (m/s peak) ^{*5}	3.5
Maximum Disp.	Sine (mmp-p)	76.2
	High Velocity Shock (mmp-p)	76.2
Maximum Travel (mmp-p)	82	
Maximum Load (kg)	1,000	
Power Requirements (kVA) ^{*2}	100	
Breaker Capacity (A) ^{*3}	250	

Vibration Generator (A74)	
Armature Mass (kg)	74
Armature Diameter (φ mm)	446
Armature Resonance (Hz)	1,770
Allowance Eccentric Moment (N·in)	1,550
Mass (kg)	4,200

Power Amplifier (EM10HAG-A74)	
Maximum Output (kVA)	118
Mass (kg)	2,400

Cooling (VAPE900/N2R)		
Mass (kg)	320	
Cooling Air Flow (m ³ /min)	70	
Environmental Data		
Input Voltage Supply (3 φ, V)	380/400/415/440	
Compressed Air Supply (Mpa)	0.7	
Working Ambient Temperature	Shaker (°C)	0-40
	Amplifier (°C)	0-40

Vibration Generator (A74)

a: W 1,310 mm
b: H 1,253 mm
c: D 1,040 mm

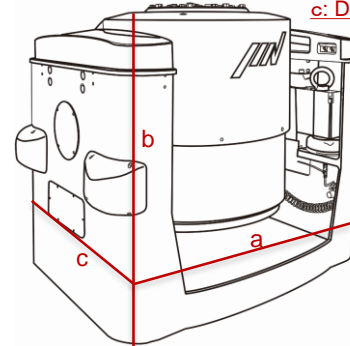
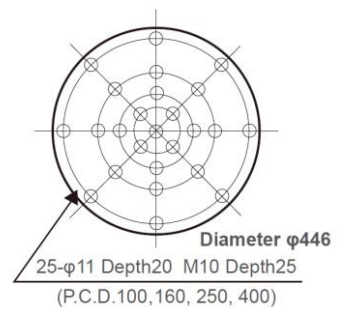
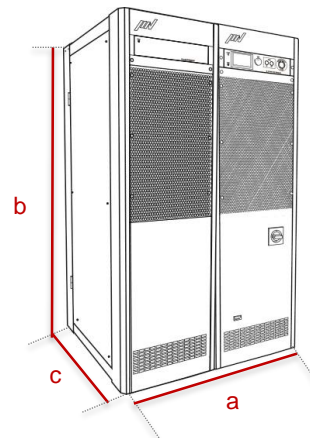

Table Insert Pattern (unit: mm)



Amplifier

a: W 1,160mm
b: H 1,950mm
c: D 850mm



Blower

a: W 1,462 mm
b: H 2,800 mm
c: D 930 mm

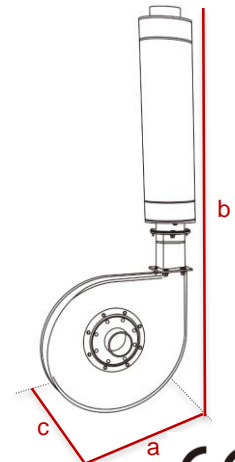

^{*1} Random force ratings are specified in accordance with ISO5344 conditions. Please contact IMV or your local distributor with specific test requirements.

^{*2} Power supply: 3-phase 380/400/415/440 V, 50/60 Hz. A transformer is required for other supply voltages.

^{*3} Breaker capacity for 480 V.

^{*4} Above 4000 Hz, the force rolls-off at a rate of -6 dB/oct.

^{*5} Maximum velocity 4.6 m/s. High velocity restricts maximum Shock force.

The specification shows the maximum system performance. For long-duration tests, system must be de-rated up to 70%.

Continuous use at maximum levels may cause failure. Please contact IMV if your system operates at more than 70%.

^{*}For random vibration tests, please set the test definition of the peak value of acceleration waveform to operate at less than the maximum acceleration of shock.

^{*}Frequency range values vary according to the sensor and vibration controller.

^{*}Armature mass and acceleration may change when a chamber is added.

IMV CORPORATION

